

Art.-Number: 703933

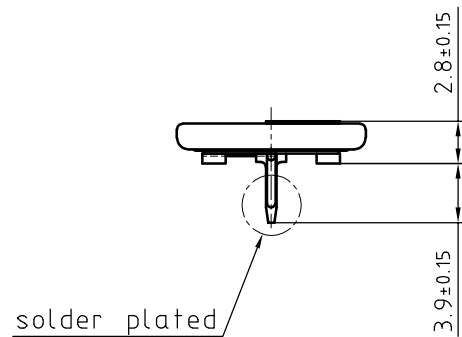
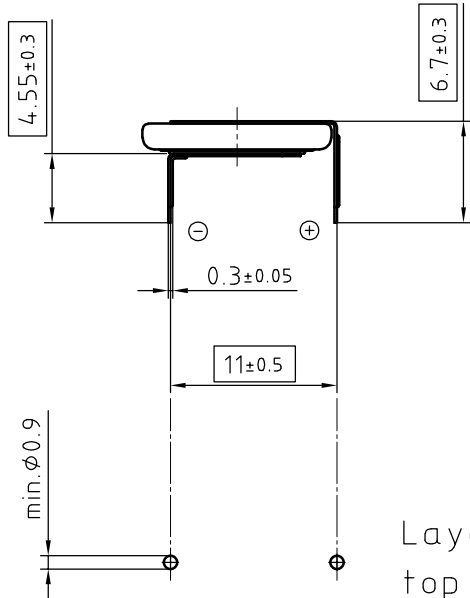
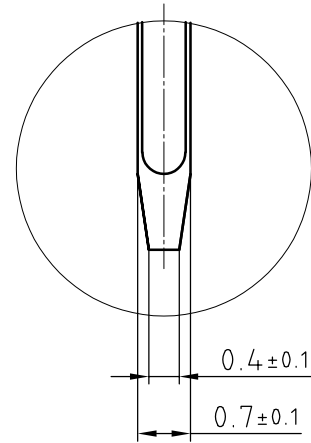
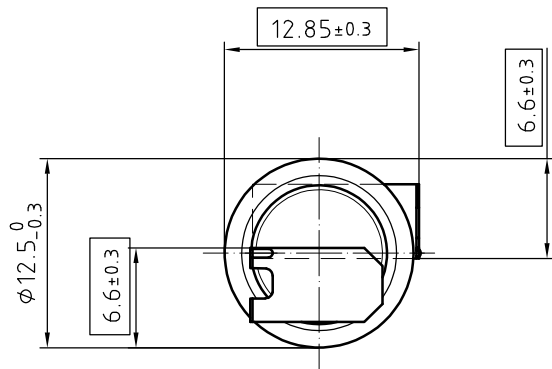

Layout  
top view

- Samples can deviate in the execution from the serie.

Tab material: Stainless steel

Direction of tab corrugation could be to the inner side, or outer side

All dimensions in mm.

- Dimensions and tolerances can be specified only after the testing of the devices for the mass production definitely

© 2018 by Renata SA Itingen/Switzerland

All framed values will be used for dimension checking !

The Products of Renata SA are neither designed nor authorized for use in certain areas of application of environment.  
For further details we refer to our webpage [www.renata.com/downloads/restriction\\_of\\_use](http://www.renata.com/downloads/restriction_of_use)

Rev.	①	23.08.19	PWu	Rev.	○				Customer's Approval				
Rev.	②	16.08.24	DPLi	Rev.	○				Date				
Rev.	○			Rev.	○				Signature				
Title:								Scale 2:1	Drawn	18.05.18	PWu		
CR1220 MFR FH									Checked	11.10.24	HSn		
									Approved	11.10.24	RFr		
								CH-4452 Itingen Switzerland			10.1752.4-2		